

## Lebensmittelschläuche Food Hoses

### Eingebunden mit Klemmschalen hose assembly with clamp collar

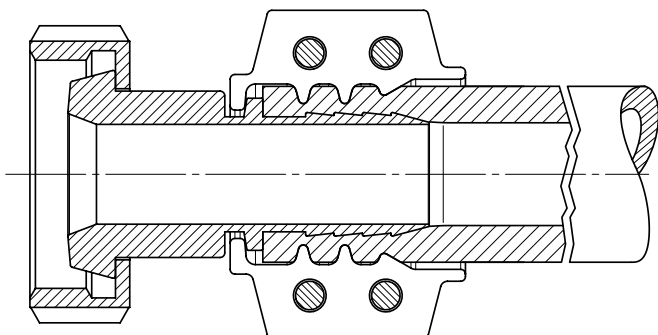

### Eingebunden mit Presshülse hoses with compressed hollow shaft

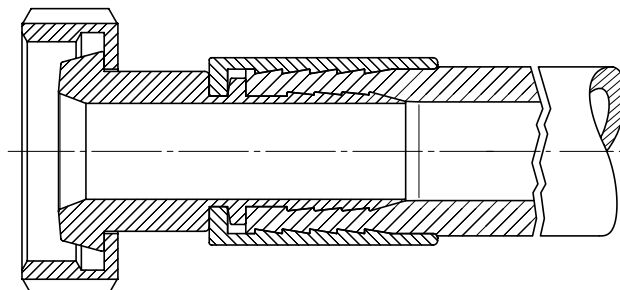

#### Einsatzgebiete

Die Schläuche werden bei verfahrenstechnischen Anlagen für gasförmige und flüssige Medien sowie für Schüttgüter eingesetzt. Bevorzugte Anwendungsgebiete sind die Biotechnik, Chemie-, Kosmetik-, Pharma-, Lebensmittel- und Getränkeindustrie.

#### Beschaffenheit

Es werden Gummi-, PVC- und PTFE-Schläuche angeboten. Die Gummischläuche bestehen in der Regel aus einer produktberührten Innenseele, einer Einlage zu Stabilisierung und einer schützenden Außendecke. Die Konfektionierung mit den gewünschten Anschluss-Armaturen wie z.B. Stutzen nach DIN 32676, DIN 11851, SMS und DIN 11864 erfolgt je nach Kundenwunsch mit Klemmschalen, Presshülsen oder einfachen Schellen. Für hohe hygienische und aseptische Anforderungen können die Schläuche mit einem PTFE-Liner ausgekleidet werden, der bis auf die stirnseitige Dichtfläche der Anschlussarmatur gezogen wird.

#### Merkmale

- Größen: DIN-DN10 -100, ASME DN1"- 4", ISO DN13,5 -114,3
- Schläuche: EPDM, VMQ, PVC, PTFE
- Einbindung: Klemmschalen, Presshülsen, Schellen
- Armaturen: Werkstoffe AISI304, 316L  
Klemmverbindung DIN 32676  
Rohrverschraubung DIN 11851  
Aseptik Rohrverschraubung DIN 11864-1  
Aseptik Flanschverbindung DIN 11864-2  
Aseptik Klemmverbindung DIN 11864-3  
Andere Schlauchanschlüsse auf Anfrage

#### Application

The hoses are used with process engineering facilities for gaseous and liquid media as well as for bulk goods. Preferential fields of application are bio-engineering, chemical, cosmetic, pharmaceutical, food and beverage industry.

#### Design

Rubber-, PVC and PTFE hoses are offered. Normally the hoses consist of an inner lining which comes in contact with the medium, a reinforced layer for stability and an outer cover for protection. The assembly with the demanded joint fittings e.g. according to DIN 32676, DIN 1151, SMS and DIN 11864 can be effected by clamping shells, press sleeves or simple hose clips. For high hygienic and aseptic requirements the hoses can be equipped with a PTFE-lining which is drawn up to the frontal sealing surface of the joint fittings.

#### Features

- Sizes: DIN-DN10 -100, ASME DN1"- 4", ISO DN13,5 -114,3
- Hoses: EPDM, VMQ, PVC, PTFE
- Assembly: Hose clamp collar, press shells, hose clips
- Fittings: Materials AISI304, 316L  
Clamp pipe connection DIN 32676  
Screwed pipe connection DIN 11851  
Aseptic screwed pipe connection DIN 11864-1  
Aseptic flange pipe connection DIN 11864-2  
Aseptic clamp pipe connection DIN 11864-3  
Other hose connections on demand

Artikel	Seite
Schläuche .....	356
Schlauchstutzen.....	366
Klemmschalen, Presshülsen, Schellen .....	375

Articles	Page
Hoses .....	356
Hose nozzles .....	366
Hose clamp collar, press shells, hose clips.....	375

Gummi-Schläuche	DN	Anwendungshinweise	Innenseele	Außendecke	Einlagen	Druck, +20 °C Sicherheitsfaktor 3	Vakuüm, +20 °C	Temperatur
Getränke-Schlauch Druckschlauch	13 - 100	alkohol. Getränke max. 40 Vol.%, fettfreie Lebensmittel	EPDM, weiß, glatt, FDA- u. BfR Kat II- konform	EPDM, rot, stoffgemustert abrieb-, UV- u. ozonbeständig	synthetische Textileinlage	15 bar	0,5 bis 0,4 bar	-40 bis +95 °C/60 min. Dampfsterilisierbar +130 °C/30 min. drucklos
Getränke-Schlauch Saug- u. Druckschlauch	19 - 100	"	"	"	synthetische Textileinlage verdeckte Stahdrahtspirale	"	0,8 bar	"
Lebensmittel-Schlauch Premium Druckschlauch	19 - 100	Getränke u. Lebensmittel aller Art, Pharma, Kosmetika, alkoholische Getränke max. 96 Vol.%, Fette, Öle	UPE, transparent, glatt FDA- u. BfR Kat II- konform	CR blau, stoffgemustert, glatt, abrieb- u. witterungsbeständig	Gewebe, hochreißfest	15 bar	0,5 bis 0,4 bar	-30 bis +90 °C/60 min. Dampfsterilisierbar +130 °C/30 min. drucklos
Lebensmittel-Schlauch Premium Saug- u. Druckschlauch	19 - 100	"	"	"	Gewebe, hochreißfest verdeckte Stahdrahtspirale 2 gekreuzte Kupferlitzen	"	0,8 bar	"
Lebensmittel-Schlauch leicht Saug- u. Druckschlauch	19 - 100	fettthaltige u. nicht fettthaltige Lebens- mittel aller Art, alkoholische Getränke max. 96 Vol.%	synth. Compound, weiß, glatt FDA-konform	synth. Compound, grau, glatt abriebfest	synthetische Textileinlage verdeckte Stahdrahtspirale	je nach NW 5 bis 18 bar	0,8 bar	-20 bis +80 °C Dampfsterilisierbar +130 °C/30 min. drucklos
Molkerei-Schlauch Druckschlauch	13 - 100	fettthaltige u. fettfreie Lebensmittel aller Art, nicht geeignet für Alkohol und abrasive Medien	NBR, weiß, glatt FDA- u. BfR Kat II- konform	Spezialcompound, blau, glatt, stoffgemustert	synthetische Textil	15 bar	0,5 bis 0,4 bar	-20 bis +90 °C/60 min. Dampfsterilisierbar +120 °C/30 min. drucklos
Molkerei-Schlauch Saug- u. Druckschlauch	19 - 100	"	"	"	synthetische Textileinlage verdeckte Stahdrahtspirale	"	0,8 bar	"
Milch-Förderschlauch Saug- u. Druckschlauch	40 - 100	fettthaltige Medien bis 5% Fettanteil, hochflexibel	NR weiß, glatt FDA- u. BfR Kat II- konform	NR, blau, glatt, stoffgemustert, abriebfest	synthetische Textileinlage verdeckte Stahdrahtspirale	5 bar	0,8 bar	-20 bis +80 °C Dampfsterilisierbar +120 °C/30 min. drucklos
Pharma-Universal- Schlauch Saug- u. Druckschlauch	13 - 100	Lebensmittel, Chemie, Pharmazie, Kosmetika, alkoholische Getränke max. 96 Vol.%, Fette, Öle, elektrisch leitfähig durch Band-streifen	UPE, weiß, glatt, elektr. Leitfähig durch schwarzen Bandstreifen R<10 <sup>5</sup> Ohm FDA- u. BfR Kat II- konform	EPDM, schwarz-weiß keine Abriebspuren auf hellen Böden.	synthetische Textileinlage verdeckte Stahdrahtspirale	16 bar	0,9 bar	-40 bis +95 °C/60 min. Dampfsterilisierbar +130 °C/30 min. drucklos
Pharma-Spezial- Schlauch Saug- u. Druckschlauch	13 - 75	Lebensmittel, Chemie, Pharmazie, Kosmetika, alkohol. Getränke max. 96 Vol.%, Fette, Öle, elektrisch leitfähig durch Kupferlitzen	MFA (perfluoralkoxy Polymer), weiß, glatt FDA- und USP VI- konform	EPDM, weiß, stoffgemustert FDA-konform	synthetische Textileinlage verdeckte Edeldrahtspirale 2 gekreuzte Kupferlitzen	10 bar	0,9 bar	-40 bis +170 °C/60 min. Dampfsterilisierbar +140 °C/30 min. drucklos
Dampf-Schlauch Druckschlauch	13 - 65	fettfreie Lebensmittel, alkoholische Getränke max. 40 Vol.%, Dampf, Heißwasser	EPDM, weiß, glatt, FDA- u. BfR Kat II- konform	EPDM, blau, stoffgemustert abrieb- u. witterungsbeständig	synthetische Textileinlage	18 bar/+95 °C 6 bar/+164 °C	-	Heißwasser -40 bis +95 °C Dampfsterilisierbar +164 °C
Trinkwasser-Schlauch Druckschlauch	10 - 50	Wasser sehr gute Beständigkeit bei Reinigungs- u. Desinfektionsmitteln, Säuren u. Laugen	UPE, semi-transparent, glatt FDA- u. BfR Kat II- konform KTW-A Zulassung DVGW W-270 Prüfung	EPDM, blau, stoffgemustert abrieb-, UV- u. ozonbeständig	synthetische Textileinlage	20 bar	-	Trinkwasser: -30 bis +55 °C Reinigungsmittel: -30 bis +90 °C Dampfsterilisierbar +120 °C/30 min. drucklos
Wein-Schlauch Saug- u. Druckschlauch	32 - 100	fettfreie Lebensmittel, alkoholische Getränke max. 40 Vol.%, leichter Schlauch	EPDM, weiß, glatt, FDA-konform	EPDM, schwarz, mit orangener PE-Spirale für guten Scheuer- schulz u. leichtes Gleiten auf dem Boden	synthetische Textileinlage	je nach NW 5 bis 8 bar	0,8 bar	-40 bis +70 °C Dampfsterilisierbar +120 °C/30 min. drucklos

Silikon-Schläuche	DN	Geeignet für	Innenseele	Außendecke	Einlagen	Druck, +20 °C Sicherheitsfaktor 3	Vakuum, +20 °C	Temperatur
Silikon-Standard-Laborschlauch	2 - 50	Lebensmittel, Chemie, Pharmazie druckloser Einsatz	Silikon peroxid vernetzt, transparent, glatt FDA- u. BFR-konform	-	-	-	-	-60 bis +200 °C
Silikon-Pharma-Laborschlauch	2 - 15	Lebensmittel, Chemie, Pharmazie druckloser Einsatz	Silikon ultrarein, transparent, glatt, FDA-, BFR- u. USP VI-konform, PH Eur 3	-	-	-	-	-60 bis +200 °C
Silikon-Gewebeschauch Druckschlauch	3 - 25	Lebensmittel, Chemie, Pharmazie für hohe Temperaturen	Silikon peroxid vernetzt, transparent, glatt FDA- u. BFR XV-konform	Silikon, transparent, glatt	Glasseidengewebe	je nach NW 5 bis 20 bar	-	-55 bis +180 °C Dampfsterilisierbar +130 °C/30 min.
Silikon-Schlauch, peroxidvernetzt Druckschlauch	4 - 20	Lebensmittel, Chemie, Pharmazie für hohe Temperaturen	Silikon peroxid vernetzt, transparent, glatt FDA- u. BFR XV-konform	Silikon, rot, glatt	Monofilgewebeeinlage	je nach NW 6 bis 20 bar	-	-55 bis +160 °C Dampfsterilisierbar +130 °C/30 min.
Silikon-Schlauch, platinvernetzt Saug- u. Druckschlauch	16 - 102	Lebensmittel, Chemie, Pharmazie, für hohe Temperaturen, sehr flexibel	Silikon platin-vernetzt, transluzent-natur, glatt FDA-, BFR XV u. USP VI-konform	Silikon platin-vernetzt, transluzent-natur, glatt	Polyestergewebeeinlage Edelstahlspirale	je nach NW 5 bis 15 bar	0,8 bar	-40 bis +200 °C Dampfsterilisierbar +130 °C/30 min.
PVC-Schläuche	NW	Geeignet für	Innenseele	Außendecke	Einlagen	Druck, 20 °C Sicherheitsfaktor 3	Vakuum, 20 °C	Temperatur
PVC-Getränke-Schlauch, Gewebe Druckschlauch	4 - 50	alkohol. Getränke max. 13 Vol.%, Druckluft, Wasser, nicht geeignet für Öle, Fette, Milch, Bier	PVC weich, transparent, glatt	PVC weich, transparent, glatt	Gewebe	je nach NW 5 bis 24 bar	-	-10 bis +40 °C Wasser +60 °C
PVC-Getränkeschlauch, PCV-Spirale Saug- u. Druckschlauch	20 - 100	alkohol. Getränke max. 28 Vol.%, nicht geeignet für Öle, Fette, Milch, Bier Standardschlauch im Weinbau	PVC weich, transparent, glatt	PVC Spirale, rot, hart	-	je nach NW 4 bis 8 bar	0,8 bar	-10 bis +40 °C Wasser +60 °C
PVC-Getränkeschlauch, Metall-Spirale Saug- u. Druckschlauch	12 - 100	alkohol. Getränke max. 28 Vol.%, nicht geeignet für Öle, Fette, Milch, Bier	PVC weich, transparent, glatt	PVC weich, transparent, glatt	verdeckte Stahldrahtspirale	je nach NW 3 bis 15 bar	0,8 bar	-10 bis +40 °C Wasser +60 °C
PTFE-Schläuche	NW	Geeignet für	Innenseele	Außendecke	Einlagen	Druck, 20 °C Sicherheitsfaktor 3	Vakuum, 20 °C	Temperatur
PTFE-Glattschlauch, umflochten	5 - 26,4	Lebensmittel, Chemie, Pharmazie	PTFE-Schlauch, weiß, glatt FDA-konform	Edelstahlgewebe 1-lagig 1,4301	-	je nach NW 50 bis 280 bar >130 °C; je 1 °C um 0,5% reduzieren	0,8 bar	-70 bis +260 °C druck- u. mediumabhängig
PTFE-Wellenschlauch, umflochten	9,5 - 50	Lebensmittel, Chemie, Pharmazie	PTFE Schlauch, weiß, gewellt FDA-konform	Edelstahlgewebe 1-lagig 1,4301	-	je nach NW 15 bis 80 bar >130 °C; je 1 °C um 0,5% reduzieren	bis DN25 0,8 bar	-70 bis +260 °C druck- u. mediumabhängig
PTFE-Wellenschlauch, umflochten, Spirale	15 - 100	Lebensmittel, Chemie, Pharmazie	PTFE Schlauch, weiß, schräg gewellt mit außenliegender Edelstahlschleife, FDA-konform	Edelstahlgewebe 1-lagig 1,4301	-	je nach NW 10 bis 41 bar >130 °C; je 1 °C um 0,5% reduzieren	0,8 bar	-70 bis +260 °C druck- u. mediumabhängig
PTFE-Wellenschlauch, umflochten, flexibel	10 - 50	Lebensmittel, Chemie, Pharmazie	PTFE-Schlauch, weiß innen glatt, außen gewellt FDA-konform	Edelstahlgewebe 1-lagig 1,4301	-	je nach NW 30 bis 80 bar >130 °C; je 1 °C um 0,5% reduzieren	0,8 bar	-70 bis +260 °C druck- u. mediumabhängig
PTFE-Schlauch, umflochten, Silikondecke	6 - 25	Lebensmittel, Chemie, Pharmazie	PTFE-Schlauch, weiß innen glatt, außen gewellt FDA- u. USP VI-konform	Edelstahlgewebe 1-lagig 1,4301 weiße Silikon-Decke	-	je nach NW 50 bis 130 bar >130 °C; je 1 °C um 0,5% reduzieren	0,8 bar	-70 bis +200 °C druck- u. mediumabhängig

Rubber-hoses	DN	Application remarks	Inner hose cover	Outer hose cover	Core	Pressure, +20 °C Safety factor 3	Vacuum, +20 °C	Temperature
Beverage hose Pressure hose	13 - 100	alcoholic drinks max. 40 Vol.%, greaseless food	EPDM, white, smooth, FDA- u. BfR Kat II- conform	EPDM, red, stuff patterned, abrasion, UV and ozon resistant	synthetic textile core	15 bar	depending on dimension 0,5 up to 0,4 bar	-40 up to +95 °C/60 min. steam sterilisation +130 °C/30 min. pressureless
Beverage hose Suction and pressure hose	19 - 100	"	"	"	synthetic textile core covered metal spiral	"	0,8 bar	"
Food hose premium Pressure hose	19 - 100	drinks and food of any sort, pharmaceuticals, cosmetics, alcoholic drinks max. 96 Vol.%, fat, oils	UPE, translucent, smooth, FDA- u. BfR Kat II- conform	CR blue, stuff patterned, smooth, abrasion and weather resistant	fabric, high tear-resistant	15 bar	depending on dimension 0,5 up to 0,4 bar	-30 up to +90 °C/60 min. steam sterilisation +130 °C/30 min. pressureless
Food hose premium Suction and pressure hose	19 - 100	"	"	"	fabric, high tear-resistant covered metal spiral 2 crossbred copper litz	"	0,8 bar	"
Food hose light Suction and pressure hose	19 - 100	fatty and greaseless food of any sort, alcoholic drinks max. 96 Vol.%	synthetic compound, white, smooth FDA-conform	synthetic compound, grey, smooth abrasion resistant	fabric, high tear-resistant covered metal spiral	depending on dimension 5 bis 18 bar	0,8 bar	-20 up to +80 °C steam sterilisation +130 °C/30 min. pressureless
Dairy hose Pressure hose	13 - 100	fatty and greaseless food of any sort, unfit for alcohol and abrasive fluids	NBR, white, smooth FDA- u. BfR Kat II- conform	Special compound, blue, smooth, stuff patterned	synthetic textile core	15 bar	depending on dimension 0,5 up to 0,4 bar	-20 up to +90 °C/60 min. steam sterilisation +120 °C/30 min. pressureless
Dairy hose Suction and pressure hose	19 - 100	"	"	"	synthetic textile core fabric, high tear-resistant covered metal spiral	"	0,8 bar	"
Milk transport hose Suction and pressure hose	40 - 100	fluids up to 5% fatt rate, very flexible	NR white, smooth FDA- u. BfR Kat II- conform	NR, blue, smooth, stuff patterned, abrasion resistant	synthetic textile core covered metal spiral	5 bar	0,8 bar	-20 up to +80 °C steam sterilisation +120 °C/30 min. pressureless
Pharmacy hose universal Suction and pressure hose	13 - 100	food, chemistry, pharmaceuticals, cosmetics, alcoholic drinks max. 96 Vol.%, fatt, oil, electroconductive by black strip R < 10 <sup>5</sup> Ohm	UPE, white, smooth, FDA- u. BfR Kat II- conform	EPDM, black-white no abrasion marks on patten floors	synthetic textile core covered metal spiral	16 bar	0,9 bar	-40 up to +95 °C/60 min. steam sterilisation +130 °C/30 min. pressureless
Pharmacy hose special Suction and pressure hose	13 - 75	food, chemistry, pharmaceuticals, cosmetics, alcoholic drinks max. 96 Vol.%, fatt, oil, electroconductive by copper litz	MFA (perfluoralkoxy Polymer), white, smooth FDA- und USP VI- conform	EPDM, white, stuff pattern FDA-conform	synthetic textile core covered metal spiral 2 crossbred copper litz	10 bar	0,9 bar	-40 up to +170 °C/60 min. steam sterilisation +140 °C/30 min. pressureless
Steam hose Pressure hose	13 - 65	greaseless food, alcoholic drinks max. 40 Vol.%, steam, hot water	EPDM, white, smooth, FDA- u. BfR Kat II- conform	EPDM, blue, stuff pattern abrasion and wheather resistant	synthetic textile core	18 bar/+95 °C 6 bar/+164 °C	-	hot water -40 bis +95 °C steam sterilisation +164 °C
Drinking water hose Pressure hose	10 - 50	water, very good resistance against cleaning agents, desinfectant, acid and base	UPE, semi-translucent, smooth FDA- u. BfR Kat II- conform KTW-A certification DVGW W-270 Prüfung	EPDM, blue, stuff pattern abrasion, UV and ozon resistant	synthetic textile core	20 bar	-	drinking water: -30 up to +55 °C cleaning agent: -30 up to +90 °C steam sterilisation +120 °C/ 30 min. pressureless*
Wine hose Suction and pressure hose	32 - 100	alcoholic drinks max. 40 Vol.%, greaseless food, light hose	EPDM, white, smooth, FDA-conform	EPDM, black, with orange coloured PE-wire spiral warp	synthetic textile core	depending on dimension 5 bis 18 bar	0,8 bar	-40 up to +70 °C steam sterilisation +120 °C/ 30 min. pressureless

Silicone-hoses	DN	Application remarks	Inner hose cover	Outer hose cover	Core	Pressure, +20 °C Safety factor 3	Vacuum, +20 °C	Temperature
Silicone-standard-laboratory hose	2 - 50	Food, chemistry, pharmaceuticals, pressureless use	Silicone peroxid cross-linked, translucent, smooth FDA- u. BFR-conform	-	-	-	-	-60 up to +200 °C
Silicone-pharmacy-laboratory hose	2 - 15	Food, chemistry, pharmaceuticals, pressureless use	Silicone peroxid cross-linked, translucent, smooth, FDA- u. BFR- u. USP VI-conform, PH Eur 3	-	-	-	-	-60 up to +200 °C
Silicone-fabric-hose Pressure hose	3 - 25	Food, chemistry, pharmaceuticals, high temperatures	Silicone peroxid cross-linked, translucent, smooth FDA- u. BFR XV-conform	Silicone, translucent, smooth	Glass fibre fabric	depending on dimension 5 up to 20 bar	-	-55 up to +180 °C steam sterilisation +130 °C/30 min.
Silicone-hose, peroxid cross-linked Pressure hose"	4 - 20	Food, chemistry, pharmaceuticals, high temperatures	Silicone peroxid cross-linked, translucent, smooth FDA- u. BFR XV-conform	Silicone, red, smooth	Monofil fabric	depending on dimension 6 up to 20 bar	-	-55 up to +160 °C steam sterilisation +130 °C/30 min.
Silicone-hose, platin cross-linked Suction and pressure hose	16 - 102	Food, chemistry, pharmaceuticals, high temperatures, very flexible	Silicone peroxid cross-linked, translucent, smooth FDA-, BFR XV u. USP VI-conform	Silicone platin cross-linked translucent, smooth	Polyester fabric stainless steel spiral	depending on dimension 5 up to 15 bar	0,8 bar	-40 bis +200 °C steam sterilisation +130 °C/30 min.
PVC-hoses	DN	Application remarks	Inner hose cover	Outer hose cover	Core	Pressure, +20 °C Safety factor 3	Vacuum, +20 °C	Temperature
PVC-beverage-hose, fabric Pressure hose	4 - 50	Alcoholic drinks max. 13 Vol.%, compressed air, water. Not usable for oil, fat, milk, beer	PVC soft, translucent, smooth	PVC soft, translucent, smooth	fabric	depending on dimension 5 bis 24 bar	-	-10 up to +40 °C water: +60 °C
PVC-beverage-hose, PVC-spiral Suction and pressure hose	20 - 100	Alcoholic drinks max. 28 Vol.%, compressed air, water. Not usable for oil, fat, milk, beer standard hose winegrowing	PVC soft, translucent, smooth	PVC spiral, red, hard	-	depending on dimension 4 bis 8 bar	0,8 bar	-10 up to +40 °C water: +60 °C
PVC-beverage-hose, metall-spiral Suction and pressure hose	12 - 100	Alcoholic drinks max. 28 Vol.%, compressed air, water. Not usable for oil, fat, milk, beer	PVC soft, translucent, smooth	PVC soft, translucent, smooth	covered metal spiral	depending on dimension 3 bis 15 bar	0,8 bar	-10 up to +40 °C water: +60 °C
PTFE-hoses	DN	Application remarks	Inner hose cover	Outer hose cover	Core	Pressure, +20 °C Safety factor 3	Vacuum, +20 °C	Temperature
PTFE waveless hose, braided	5 - 26,4	Food, chemistry, pharmaceuticals	PTFE-hose, white, smooth, FDA-conform	stainless-steel mashwork 1.4301, one coat	-	depending on dimension 50 up to 280 bar >130 °C; each 1 °C reduce 0,5%	0,8 bar	-70 up to +260 °C, depending on pressure and fluid
PTFE flexible hose, braided	9,5 - 50	Food, chemistry, pharmaceuticals	PTFE-hose, white, waved, FDA-conform	stainless-steel mashwork 1.4301, one coat	-	depending on dimension 15 bis 80 bar >130 °C; each 1 °C reduce 0,5%	up to DN25 0,8 bar	-70 up to +260 °C, depending on pressure and fluid
PTFE flexible hose, braided, spiral	15 - 100	Food, chemistry, pharmaceuticals	PTFE-hose, white, transversal waved with outer stainless steel spiral, FDA-conform	stainless-steel mashwork 1.4301, one coat	-	depending on dimension 10 up to 41 bar >130 °C; each 1 °C reduce 0,5%	0,8 bar	-70 up to +260 °C, depending on pressure and fluid
PTFE flexible hose, waveless, braided	10 - 50	Food, chemistry, pharmaceuticals	PTFE-hose, white, inside smooth, outside waved, FDA-conform	stainless-steel mashwork 1.4301, one coat	-	depending on dimension 30 up to 80 bar >130 °C; each 1 °C reduce 0,5%	0,8 bar	-70 up to +260 °C, depending on pressure and fluid
PTFE flexible hose, waveless, braided, silicone cover	6 - 25	Food, chemistry, pharmaceuticals	PTFE-hose, white, inside smooth, outside waved, FDA- and USP VI-conform	stainless-steel mashwork 1.4301, one coat, white silicone cover	-	depending on dimension 50 up to 130 bar >130 °C; each 1 °C reduce 0,5%	0,8 bar	-70 up to +200 °C, depending on pressure and fluid

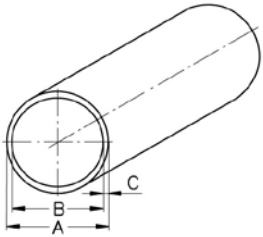
Lebensmittelschläuche							Art.No.	EUR	Art.No.	EUR
<b>Getränke-Schlauch</b> <b>Beverage hose</b> 	DN	A	B	C	Druck Pressure bar, 20°C	Vakuum Vacuum bar, 20°C	Druckschlauch Pressure hose EPDM-EPDM		Saug- +Druckschlauch Suction +pressure hose EPDM-EPDM	
	13x5	23	13	5	15	0,5	6101-13x5	Anfrage	-	-
	19x6	31	19	6	15	0,5	6101-19x6	Anfrage	6102-19x6	Anfrage
	25x6	37	25	6	15	0,5	6101-25x6	Anfrage	6102-25x6	Anfrage
	32x6	44	32	6	15	0,8	-	-	6102-32x6	Anfrage
	32x8	48	32	8	15	0,5	6101-32x8	Anfrage	-	-
	38x6,5	51	38	6,5	15	0,8	-	-	6102-38x6,5	Anfrage
	38x9	56	38	9	15	0,5	6101-38x9	Anfrage	-	-
	40x7	54	40	7	15	0,8	-	-	6102-40x7	Anfrage
	40x10	60	40	10	15	0,5	6101-40x10	Anfrage	-	-
	50x8	66	50	8	15	0,8	-	-	6102-50x8	Anfrage
	50x11	72	50	11	15	0,5	6101-50x11	Anfrage	-	-
	65x8	81	65	8	15	0,4	-	-	6102-65x8	Anfrage
	75x8	91	75	8	15	0,4	-	-	6102-75x8	Anfrage
	80x9	98	80	9	15	0,4	-	-	6102-80x9	Anfrage
102x9	120	102	9	15	0,4	-	-	6102-102x9	Anfrage	

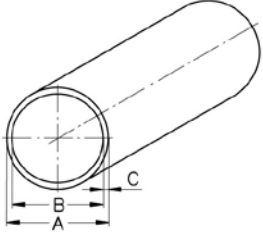
<b>Lebensmittel-Schlauch, Premium</b> <b>Food hose premium</b> 	DN	A	B	C	Druck Pressure bar, 20°C	Vakuum Vacuum bar, 20°C	Druckschlauch Pressure hose UPE-CR		Saug- +Druckschlauch Suction +pressure hose UPE-CR	
	25x6	37	25	6	15	0,5	6103-25x6	Anfrage	6104-25x6	Anfrage
	32x6	44	32	6	15	0,8	-	-	6104-32x6	Anfrage
	32x8	48	32	8	15	0,5	6103-32x8	Anfrage	-	-
	38x6,5	51	38	6,5	15	0,8	-	-	6104-38x6,5	Anfrage
	38x9	56	38	9	15	0,5	6103-38x9	Anfrage	-	-
	40x7	54	40	7	15	0,8	-	-	6104-40x7	Anfrage
	40x10	60	40	10	15	0,5	6103-40x10	Anfrage	-	-
	50x8	66	50	8	15	0,8	-	-	6104-50x8	Anfrage
	50x11	72	50	11	15	0,5	6103-50x11	Anfrage	-	-
	65x8	81	65	8	15	0,4	-	-	6104-65x8	Anfrage
	75x8	91	75	8	15	0,4	-	-	6104-75x8	Anfrage
	80x9	98	80	9	15	0,4	-	-	6104-80x9	Anfrage
	102x9	120	102	9	15	0,4	-	-	6104-102x9	Anfrage

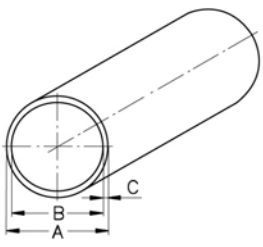
Lebensmittelschläuche							Art.No.	EUR	Art.No.	EUR
<b>Lebensmittel-Schlauch, leicht</b> <b>Food hose light</b> 	DN	A	B	C	Druck Pressure bar, 20°C	Vakuum Vacuum bar, 20°C			Saug- +Druckschlauch Suction +pressurehose synth. Compound	
	19x5	29	19	5	18	0,8			6105-19x5	Anfrage
	25x5	35	25	5	15	0,8			6105-25x5	Anfrage
	32x5	42	32	5	12	0,8			6105-32x5	Anfrage
	38x5,3	48,6	38	5,3	10	0,8			6105-38x5,3	Anfrage
	40x5,3	50,6	40	5,3	10	0,8			6105-40x5,3	Anfrage
	51x5,3	61,6	51	5,3	8	0,8			6105-51x5,3	Anfrage
	65x6	77	65	6	7	0,8			6105-65x6	Anfrage
	80x6	92	80	6	6	0,8			6105-80x6	Anfrage
	100x6,5	115	100	6,5	5	0,8			6105-100x6,5	Anfrage

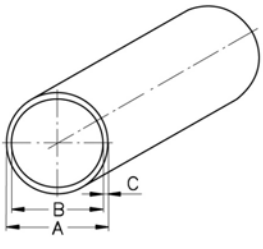
<b>Molkerei-Schlauch</b> <b>Dairy hose</b> 	DN	A	B	C	Druck Pressure bar, 20°C	Vakuum Vacuum bar, 20°C	Druckschlauch NBR-Compound		Saug- +Druckschlauch Suction +pressure hose NBR-Compound	
	13x5	23	13	5	15	0,5	6106-13x5	Anfrage	6107-13x5	Anfrage
	19x6	31	19	6	15	0,5	6106-19x6	Anfrage	6107-19x6	Anfrage
	25x6	39	25	6	15	0,5	6106-25x6	Anfrage	6107-25x6	Anfrage
	32x6	74	32	6	15	0,8	-	-	6107-32x6	Anfrage
	32x8	48	32	8	15	0,5	6106-32x8	Anfrage	-	-
	38x6,5	51	38	6,5	15	0,8	-	-	6107-38x6,5	Anfrage
	38x9	46	38	9	15	0,5	6106-38x9	Anfrage	-	-
	40x7	54	40	7	15	0,8	-	-	6107-40x7	Anfrage
	40x10	60	40	10	15	0,5	6106-40x10	Anfrage	-	-
	50x8	66	50	8	15	0,8	-	-	6107-50x8	Anfrage
	50x11	72	50	11	15	0,5	6106-50x11	Anfrage	-	-
	65x8	81	65	8	15	0,4	-	-	6107-65x8	Anfrage
	65x12	89	65	12	15	0,4	6106-65x12	Anfrage	-	-
	75x8	91	75	8	15	0,4	-	-	6107-75x8	Anfrage
	80x9	98	80	9	15	0,4	-	-	6107-80x9	Anfrage
	110x15	110	80	15	15	0,4	6106-80x15	Anfrage	-	-
	102x9	120	102	9	15	0,4	-	-	6107-102x9	Anfrage
102x15	132	102	15	15	0,4	6106-102x15	Anfrage	-	-	

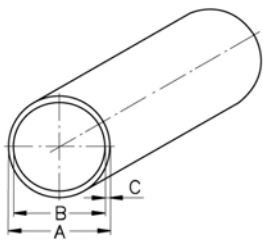
<b>Milch-Förderschlauch</b> <b>Milk delivery hose</b> 	DN	A	B	C	Druck Pressure bar, 20°C	Vakuum Vacuum bar, 20°C			Saug- +Druckschlauch Suction +pressure hose NR-NR	
	40x5	50	40	5	5	0,8			6108-40x5	Anfrage
	45x5	55	45	5	5	0,8			6108-45x5	Anfrage
	50x6	62	50	6	5	0,8			6108-50x6	Anfrage
	52x6	64	52	6	5	0,8			6108-52x6	Anfrage
	55x6	67	55	6	5	0,8			6108-55x6	Anfrage
	65x6	77	65	6	5	0,8			6108-65x6	Anfrage
	80x6,5	93	80	6,5	5	0,8			6108-80x6,6	Anfrage
100x7	114	100	7	5	0,8			6108-100x7	Anfrage	

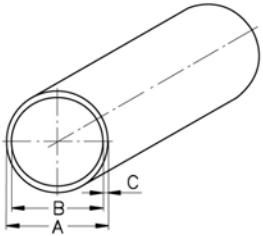
Lebensmittelschläuche							Art.No.	EUR	Art.No.	EUR
<b>Pharma-Universal-Schlauch</b> Pharmacy hose universal  	DN	A	B	C	Druck Pressure bar, 20°C	Vakuum Vacuum bar, 20°C			Saug- +Druckschlauch Suction +pressure hose UPE-EPDM	
	13x5	23	13	5	16	0,9			6109-13x5	Anfrage
	19x6	31	19	6	16	0,9			6109-19x6	Anfrage
	25x6	37	25	6	16	0,9			6109-25x6	Anfrage
	32x6	44	32	6	16	0,9			6109-32x6	Anfrage
	38x6,5	51	38	6,5	16	0,9			6109-38x6,5	Anfrage
	50x8	66	50	8	16	0,9			6109-50x8	Anfrage
	63,5x8	79,5	63	8	16	0,9			6109-63,5x8	Anfrage
	75x8	91	75	8	16	0,9			6109-75x8	Anfrage
	102x8	118	102	8	16	0,9			6109-102x8	Anfrage
<b>Auch mit schwarz-weißer Außendecke lieferbar,            dadurch keine Abriebspuren auf hellen Bodenbelägen</b> <b>Also available with black-white hose cover, thereby no            rubbed-off parts marks on bright floors covers.</b>										

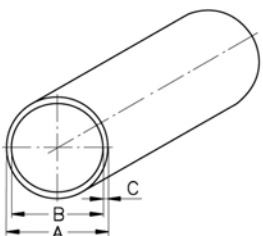
<b>Pharma-Spezial-Schlauch</b> Pharmacy hose special  	DN	A	B	C	Druck Pressure bar, 20°C	Vakuum Vacuum bar, 20°C			Saug- +Druckschlauch Suction +pressure hose MFA-EPDM	
	13x6	25	13	6	10	0,9			6110-13x6	Anfrage
	19x6	31	19	6	10	0,9			6110-19x6	Anfrage
	25x6	37	25	6	10	0,9			6110-25x6	Anfrage
	32x6,5	45	32	6,5	10	0,9			6110-32x6,5	Anfrage
	38x6,5	51	38	6,5	10	0,9			6110-38x6,5	Anfrage
	51x7,25	65,5	51	7,25	10	0,9			6110-51x7,25	Anfrage
	63,5x8	79,5	63,5	8	10	0,9			6110-63,5x8	Anfrage
	75x8	91	75	8	10	0,9			6110-75x8	Anfrage
	<b>Für eine elektrische Ableitfähigkeit müssen die 2            Kupferlitzten mit den Anschlussarmaturen verbunden            werden.</b> <b>To achieve electric conductivity the 2 copper litz wires            have to be connected with the nose nozzles.</b>									

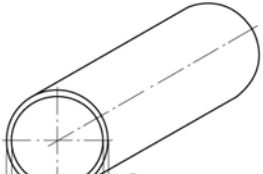
<b>Dampf-Schlauch</b> Steam hose  	DN	A	B	C	Druck Pressure bar, 20°C	Vakuum Vacuum bar, 20°C			Druckschlauch Pressure hose EPDM-EPDM	
	13x5	23	13	5	6	-			6111-13x5	Anfrage
	19x6	31	19	6	6	-			6111-19x6	Anfrage
	25x7	39	25	7	6	-			6111-25x7	Anfrage
	32x8	48	32	8	6	-			6111-32x8	Anfrage
	40x9	58	40	9	6	-			6111-40x9	Anfrage
	50x10	70	50	10	6	-			6111-50x10	Anfrage
	65x11	87	65	11	6	-			6111-65x11	Anfrage

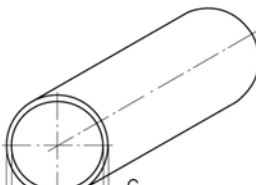

Lebensmittelschläuche							Art.No.	EUR	Art.No.	EUR
<b>Trinkwasser-Schlauch</b> <b>Drinking water hose</b> 	DN	A	B	C	Druck Pressure bar, 20°C	Vakuum Vacuum bar, 20°C			Druckschlauch Pressure hose UPE-EPDM	
	10x3,75	17,5	10	3,75	20	-			6112-10x3,75	Anfrage
	13x4,25	21,5	13	4,25	20	-			6112-13x4,25	Anfrage
	19x5	29	19	5	20	-			6112-19x5	Anfrage
	25x5	35	25	5	20	-			6112-25x5	Anfrage
	32x6,5	45	32	6,5	20	-			6112-32x6,5	Anfrage
	38x7	52	38	7	20	-			6112-38x7	Anfrage
	50x8	66	50	8	20	-			6112-50x8	Anfrage

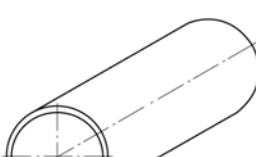
<b>Wein-Schlauch</b> <b>Wine hose</b> 	DN	A	B	C	Druck Pressure bar, 20°C	Vakuum Vacuum bar, 20°C			Saug- +Druckschlauch Suction +pressure hose EPDM-EPDM	
	32x5	42	32	5	8	0,8			6113-32x5	Anfrage
	38x5,3	49	38	5,3	8	0,8			6113-38x5,3	Anfrage
	51x5,5	62	51	5,5	8	0,8			6113-51x5,5	Anfrage
	64x6,7	78	64	6,7	6	0,8			6113-64x6,7	Anfrage
	77x7	91	77	7	6	0,8			6113-77x7	Anfrage
102x8	118	102	8	5	0,8			6113-102x8	Anfrage	

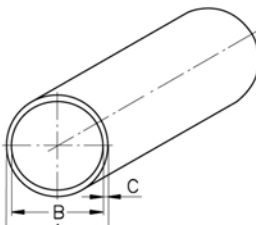
<b>Silikon-Standard-Laborschlauch</b> <b>Silicone standard laboratory hose</b> 	DN	A	B	C	Druck Pressure bar, 20°C	Vakuum Vacuum bar, 20°C			VMQ	
	2x1	4	2	1	-	-			6114-2x1	Anfrage
	3x1	8	3	1	-	-			6114-3x1	Anfrage
	4x1,5	7	4	1,5	-	-			6114-4x1,5	Anfrage
	4x2	8	4	2	-	-			6114-4x2	Anfrage
	5x1,5	8	5	1,5	-	-			6114-5x1,5	Anfrage
	5x2	9	5	2	-	-			6114-5x2	Anfrage
	6x1,5	9	6	1,5	-	-			6114-6x1,5	Anfrage
	6x2	10	6	2	-	-			6114-6x2	Anfrage
	6x3	12	6	3	-	-			6114-6x3	Anfrage
	7x1,5	10	7	1,5	-	-			6114-7x1,5	Anfrage
	7x2	11	7	2	-	-			6114-7x2	Anfrage
	7x3	13	7	3	-	-			6114-7x3	Anfrage
	8x1,5	11	8	1,5	-	-			6114-8x1,5	Anfrage
	8x2	12	8	2	-	-			6114-8x2	Anfrage
	8x3	14	8	3	-	-			6114-8x3	Anfrage
	9x1,5	12	9	1,5	-	-			6114-9x1,5	Anfrage
9x2	13	9	2	-	-			6114-9x2	Anfrage	
10x2	14	10	2	-	-			6114-10x2	Anfrage	
12x2	16	12	2	-	-			6114-12x2	Anfrage	

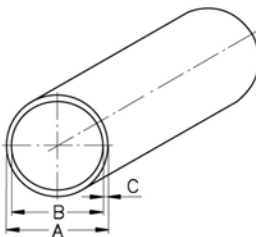
Lebensmittelschläuche							Art.No.	EUR	Art.No.	EUR
<b>Silikon-Standard-Laborschlauch</b> <b>Silicone standard laboratory hose</b> 	DN	A	B	C	Druck Pressure bar, 20°C	Vakuum Vacuum bar, 20°C			VMQ	
	12x3	18	12	3	-	-			6114-12x3	Anfrage
	14x2	18	14	2	-	-			6114-14x2	Anfrage
	15x2	19	15	2	-	-			6114-15x2	Anfrage
	15x3	21	15	3	-	-			6114-15x3	Anfrage
	16x2	20	16	2	-	-			6114-16x2	Anfrage
	16x3	22	16	3	-	-			6114-16x3	Anfrage
	18x2	22	18	2	-	-			6114-18x2	Anfrage
	18x3	24	18	3	-	-			6114-18x3	Anfrage
	20x2	24	20	2	-	-			6114-20x2	Anfrage
	20x3	26	20	3	-	-			6114-20x3	Anfrage
	22x2	26	22	2	-	-			6114-22x2	Anfrage
	22x4	30	22	4	-	-			6114-22x4	Anfrage
	24x3	30	24	3	-	-			6114-24x3	Anfrage
	25x2	29	25	2	-	-			6114-25x2	Anfrage
	25x3	31	25	3	-	-			6114-25x3	Anfrage
	25x4	33	25	4	-	-			6114-25x4	Anfrage
	28x3	34	28	3	-	-			6114-28x3	Anfrage
	30x3	36	30	3	-	-			6114-30x3	Anfrage
	35x3	41	35	3	-	-			6114-35x3	Anfrage
40x2	44	40	2	-	-			6114-40x2	Anfrage	
50x2	54	50	2	-	-			6114-50x2	Anfrage	

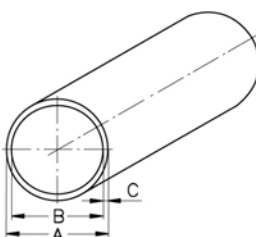
Silikon-Pharma-Laborschlauch										
<b>Silicone pharmacy laboratory hose</b> 	DN	A	B	C	Druck Pressure bar, 20°C	Vakuum Vacuum bar, 20°C			VMQ	
	2x1	4	2	1	-	-			6115-2x1	Anfrage
	3x1	8	3	1	-	-			6115-3x1	Anfrage
	4x1,5	7	4	1,5	-	-			6115-4x1,5	Anfrage
	4x2	8	4	2	-	-			6115-4x2	Anfrage
	5x1,5	8	5	1,5	-	-			6115-5x1,5	Anfrage
	5x2	9	5	2	-	-			6115-5x2	Anfrage
	6x1,5	9	6	1,5	-	-			6115-6x1,5	Anfrage
	6x2	10	6	2	-	-			6115-6x2	Anfrage
	6x3	12	6	3	-	-			6115-6x3	Anfrage
	7x1,5	13	7	1,5	-	-			6115-7x1,5	Anfrage
	7x2	11	7	2	-	-			6115-7x2	Anfrage
	7x3	13	7	3	-	-			6115-7x3	Anfrage
	8x1,5	11	8	1,5	-	-			6115-8x1,5	Anfrage
	8x2	12	8	2	-	-			6115-8x2	Anfrage
	8x3	14	8	3	-	-			6115-8x3	Anfrage
	9x2	13	9	2	-	-			6115-9x2	Anfrage
	10x2	14	10	2	-	-			6115-10x2	Anfrage
	12x2,5	17	12	2,5	-	-			6115-12x2,5	Anfrage
	15x3	21	15	3	-	-			6115-15x3	Anfrage

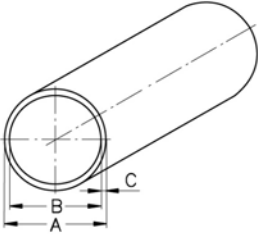
Lebensmittelschläuche							Art.No.	EUR	Art.No.	EUR
<b>Silikon-Gewebe-Schlauch</b> <b>Silicone fabric hose</b> 	DN	A	B	C	Druck Pressure bar, 20°C	Vakuum Vacuum bar, 20°C			Druckschlauch Pressure hose VMQ	
	3x2,5	8	3	2,5	20	-			6116-3x2,5	Anfrage
	4x2,5	9	4	2,5	20	-			6116-4x2,5	Anfrage
	5x3	11	5	3	15	-			6116-5x3	Anfrage
	6x3	12	6	3	12	-			6116-6x3	Anfrage
	8x3	14	8	3	10	-			6116-8x3	Anfrage
	10x4	18	10	4	9	-			6116-10x4	Anfrage
	12x4	20	12,5	4	9	-			6116-12,5x4	Anfrage
	16x5	26	16	5	7	-			6116-16x5	Anfrage
	19x5,5	30	19	5,5	7	-			6116-19x5,5	Anfrage
	25x6	37	25	6	5	-			6116-25x6	Anfrage
<p>Silikonschläuche mit Glasgewebeeinlagen sind nicht für pulsierende Drücke und Dauerdruckeinsatz an der Grenze des max. Betriebsdruckes geeignet.  Silikonschläuche sind nicht geeignet für Dampfdauerbetrieb, regelmäßige Dampfsterilisation kann zu Ausfall führen. Im Zweifelsfall nehmen Sie bitte Kontakt mit uns auf.  Silicone hoses with glass fabric core are not usable for pulsating pressures and duration of pressure applicatin on the limit of the max. operating pressure.  Silicone hoses are not suitable for continuous stem, regular steam sterilization can lead to failure. In case of doubt please contact us.</p>										

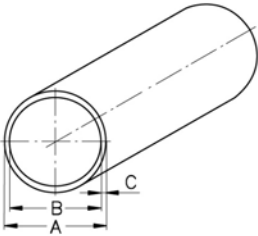
<b>Silikon-Schlauch, peroxidvernetzt</b> <b>Silicone hose peroxid cross-linked</b> 	DN	A	B	C	Druck Pressure bar, 20°C	Vakuum Vacuum bar, 20°C			Druckschlauch Pressure hose VMQ	
	4x2,5	9	4	2,5	20	-			6117-4x2,5	Anfrage
	5x3	11	5	3	15	-			6117-5x3	Anfrage
	6x3	12	6	3	12	-			6117-6x3	Anfrage
	8x3,5	15	8	3,5	12	-			6117-8x3,5	Anfrage
	9x3,8	16,6	9	3,8	10	-			6117-9x3,8	Anfrage
	10x4	18	10	4	10	-			6117-10x4	Anfrage
	12,5x4	20,5	12,5	4	9	-			6117-12,5x4	Anfrage
	16x4,5	25	16	4,5	8	-			6117-16x4,5	Anfrage
	19x5	29	19	5	7	-			6117-19x5	Anfrage
	25x5,5	31	25	5,5	6	-			6117-25x25,5	Anfrage

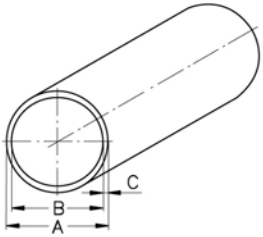
Lebensmittelschläuche							Art.No.	EUR	Art.No.	EUR
<b>Silikon-Schlauch, platinvernetzt</b> <b>Silicone hose platin cross-linked</b> 	DN	A	B	C	Druck Pressure bar, 20°C	Vakuum Vacuum bar, 20°C			Saug- +Druckschlauch Suction +pressure hose VMQ	
	16x5,5	27	16	5,5	15	0,8			6118-16x5,5	Anfrage
	19x5,5	30	19	5,5	13	0,8			6118-19x5,5	Anfrage
	25x5,5	36	25	5,5	10	0,8			6118-25x5,5	Anfrage
	32x5,5	43	32	5,5	8	0,8			6118-32x5,5	Anfrage
	38x6,5	51	38	6,5	6	0,8			6118-38x6,5	Anfrage
	40x6,5	53	40	6,5	6	0,8			6118-40x6,5	Anfrage
	50x6,5	64	50	6,5	5	0,8			6118-50x6,5	Anfrage
	65x7	79	65	7	5	0,8			6118-65x7	Anfrage
	76x7,5	91	76	7,5	6	0,8			6118-76x7,5	Anfrage
	102x7	116	102	7	5	0,8			6118-102x7	Anfrage

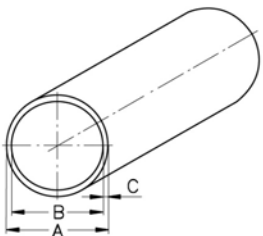
<b>PVC-Getränke-Schlauch, Gewebe</b> <b>PVC beverage hose, fabric</b> 	DN	A	B	C	Druck Pressure bar, 20°C	Vakuum Vacuum bar, 20°C			Druckschlauch Pressure hose PVC	
	4x3	10	4	3	24	-			6119-4x3	Anfrage
	5x3	11	5	3	23	-			6119-5x3	Anfrage
	6x3	12	6	3	23	-			6119-6x3	Anfrage
	8x3	14	8	3	22	-			6119-8x3	Anfrage
	9x3	15	9	3	19	-			6119-9x3	Anfrage
	10x3	16	10	3	17	-			6119-10x3	Anfrage
	12x4,5	21	12	4,5	15	-			6119-12x4,5	Anfrage
	13x3,5	20	13	3,5	13	-			6119-13x3,5	Anfrage
	16x4	24	16	4	14	-			6119-16x4	Anfrage
	19x4	27	19	4	12	-			6119-19x4	Anfrage
	25x4,5	34	25	4,5	9	-			6119-25x4,5	Anfrage
	32x5	42	32	5	7	-			6119-32x5	Anfrage
	38x5	48	38	5	6	-			6119-38x5	Anfrage
50x8	66	50	8	5	-			6119-50x8	Anfrage	

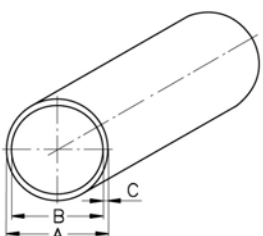
<b>PVC-Getränke-Schlauch, PVC-Spirale</b> <b>PVC beverage hose, PVC spiral</b> 	DN	A	B	C	Druck Pressure bar, 20°C	Vakuum Vacuum bar, 20°C			Saug- +Druckschlauch Suction +pressure hose PVC	
	20x3,2	26,2	20	3,2	8	0,8			6120-20x3,2	Anfrage
	25x3,8	32,6	25	3,8	8	0,8			6120-25x3,8	Anfrage
	32x4	40	32	4	8	0,8			6120-32x4	Anfrage
	40x4,5	49	40	4,5	8	0,8			6120-40x4,5	Anfrage
	50x4,5	59	50	4,5	8	0,8			6120-50x4,5	Anfrage
	63x6	75	63	6	7	0,8			6120-63x6	Anfrage
	80x6,5	93	80	6,5	5	0,8			6120-80x6,5	Anfrage
	90x7	104	90	7	5	0,8			6120-90x7	Anfrage
	100x8	116	100	8	4	0,8			6120-100x8	Anfrage

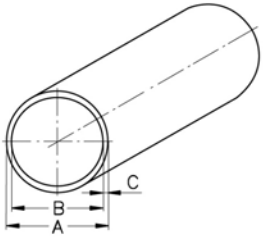
Lebensmittelschläuche							Art.No.	EUR	Art.No.	EUR
PVC-Getränke-Schlauch, Metallspirale PVC beverage hose, metal spiral 	DN	A	B	C	Druck Pressure bar, 20°C	Vakuum Vacuum bar, 20°C			Saug- +Druckschlauch Suction +pressure hose PVC	
	12x3,1	18,2	12	3,1	15	0,8			6121-12x3,1	Anfrage
	16x3,4	22,8	16	3,4	15	0,8			6121-16x3,4	Anfrage
	19x3,5	26	19	3,5	12	0,8			6121-19x3,5	Anfrage
	25x4,2	33,4	25	4,2	11	0,8			6121-25x4,2	Anfrage
	32x4,6	41,2	32	4,6	9	0,8			6121-32x4,6	Anfrage
	38x4,5	47	38	4,5	8	0,8			6121-38x4,5	Anfrage
	40x5	50	40	5	8	0,8			6121-40x5	Anfrage
	50x4,5	59	50	4,5	7	0,8			6121-50x4,5	Anfrage
	63,6x5,5	74,5	63,6	5,5	6	0,8			6121-63,6x5,5	Anfrage
	75x7	89	75	7	4	0,8			6121-75x7	Anfrage
	80x6,3	92,6	80	6,3	4	0,8			6121-80x6,3	Anfrage
	90x7	104	90	7	3	0,8			6121-90x7	Anfrage
100x8	116	100	8	3	0,8			6121-100x8	Anfrage	

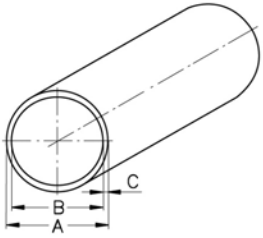
PTFE-Glattschlauch, umflochten PTFE waveless hose, braided 	DN	A	B	C	Druck Pressure bar, 20°C	Vakuum Vacuum bar, 20°C			Saug- +Druckschlauch Suction +pressure hose PTFE	
	5	7,65	5	0,76	28	0,8			6122-5x0,76	Anfrage
	6	9,3	6,7	0,76	0240	0,8			6122-6,7x0,76	Anfrage
	8	11,1	8,5	0,76	230	0,8			6122-8,5x0,76	Anfrage
	9,5	12,75	10	0,76	210	0,8			6122-10x0,76	Anfrage
	12,7	16,35	13,6	0,76	150	0,8			6122-13,6x0,76	Anfrage
	16,6	19,5	16,6	0,84	110	0,8			6122-16,6x0,84	Anfrage
	19,8	22,5	19,8	1	85	0,8			6122-19,8x1	Anfrage
	26,4	30,1	26,4	1	50	0,8			6122-26,4x1	Anfrage
	Nur mit Armaturen DIN 11851 konfektioniert lieferbar. Auch antistatisch mit ableitfähigem schwarzen PTFE lieferbar. Only available with hose nozzles DIN 11851. Also antistatic available with conductive black PTFE.									

PTFE-Wellenschlauch, umflochten PTFE flexible hose, braided 	DN	A	B	C	Druck Pressure bar, 20°C	Vakuum Vacuum bar, 20°C			Saug- +Druckschlauch Suction +pressure hose PTFE	
	9,5	13	6,3	0,63	80	0,8			6123-6,3x0,63	Anfrage
	12,5	17	9,5	0,63	60	0,8			6123-9,5x0,63	Anfrage
	16	20	12,7	0,75	50	0,8			6123-12,7x0,75	Anfrage
	19	24	16	0,89	40	0,8			6123-16x0,89	Anfrage
	25	29	22,2	1	30	0,8			6123-22,2x1	Anfrage
	32	36	28,2	1	25	-			6123-28,2x1	Anfrage

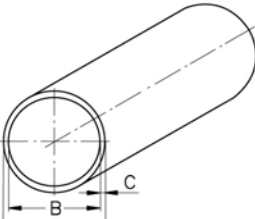
Lebensmittelschläuche							Art.No.	EUR	Art.No.	EUR
<b>PTFE-Wellschlauch, umflochten</b> <b>PTFE flexible hose, braided</b>	DN	A	B	C	Druck Pressure bar, 20°C	Vakuum Vacuum bar, 20°C			Saug- +Druckschlauch Suction +pressure hose PTFE	
	38	11	11	1,25	6	-			6123-35x1,25	Anfrage
 <p>Nur mit Armaturen DIN 11851 konfektioniert lieferbar. Auch antistatisch mit ableitfähigem schwarzen PTFE lieferbar. Only available with hose nozzles DIN 11851. Also antistatic available with conductive black PTFE.</p>										

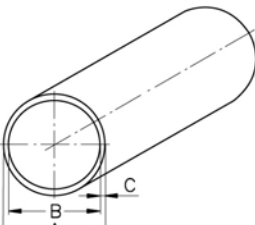
<b>PTFE-Wellschlauch, umflochten, Spirale</b> <b>PTFE flexible hose, braided, spiral</b>	DN *	A	B **	C	Druck Pressure bar, 20°C	Vakuum Vacuum bar, 20°C			Saug- +Druckschlauch Suction +pressure hose PTFE	
	15	19	9,5	1	41	0,8			6124-9,5x1	Anfrage
	20	25	14,3	1,25	35	0,8			6124-14,3x1,25	Anfrage
	25	32	20,6	1,65	31	0,8			6124-20,6x1,65	Anfrage
	32	38	25,4	1,65	27	0,8			6124-25,4x1,65	Anfrage
 <p>Nur mit Armaturen DIN 11851 konfektioniert lieferbar. Auch antistatisch mit ableitfähigem schwarzen PTFE lieferbar. Die Schläuche können auch mit PTFE-ausgekleideten Schlauchstutzen geliefert werden, das auf der Dichtfläche umbördelt wird. * nominale Nennweite ** echte Nennweite, innen-Ø zwischen den Wellen Only available with hose nozzles DIN 11851. Also antistatic available with conductive black PTFE. The hoses are also available with PTFE lined hose nozzles that will be beaded on the sealing surface. * nominal size ** real size, inner-Ø between waves</p>										

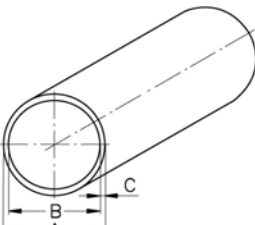
<b>PTFE-Wellschlauch, glatt, umflochten</b> <b>PTFE flexible hose, waveless, braided</b>	DN	A	B	C	Druck Pressure bar, 20°C	Vakuum Vacuum bar, 20°C			Saug- +Druckschlauch Suction +pressure hose PTFE	
	10	13	9,5	-	80	0,8			6125-9,5	Anfrage
	13	16	12,7	-	70	0,8			6125-12,7	Anfrage
	15	21	16	-	65	0,8			6125-16	Anfrage
	20	24	19	-	60	0,8			6125-19	Anfrage
	25	32	25,4	-	50	0,8			6125-25,4	Anfrage
	32	40	32	-	45	0,8			6125-32	Anfrage
	38	47	38	-	40	0,8			6125-38	Anfrage
										

Lebensmittelschläuche							Art.No.	EUR	Art.No.	EUR
PTFE-Wellenschlauch, glatt, umflochten PTFE flexible hose, waveless, braided	DN	A	B	C	Druck Pressure bar, 20°C	Vakuum Vacuum bar, 20°C			Saug- +Druckschlauch Suction +pressure hose PTFE	
	50	60	50,8	-	30	0,8			6125-50,8	Anfrage
Nur mit Schlauchstutzen konfektioniert lieferbar. Auch antistatisch mit ableitfähigem schwarzen PTFE lieferbar. Die Schläuche können auch mit PTFE ausgekleideten Schlauchstutzen geliefert werden, das auf der Dichtfläche umbördelt wird. Only available with hose nozzles ready-for-use. Also antistatic available with conductive black PTFE. The hoses are also available with PTFE lined hose nozzles that will be beaded on the sealing surface.										

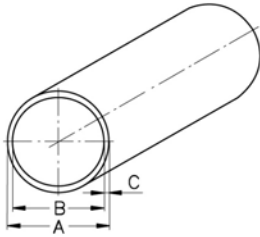

PTFE-Wellenschlauch, glatt, umflochten, Silikondecke PTFE flexible hose, braided, waveless, Silicone cover	DN	A	B	C	Druck Pressure bar, 20°C	Vakuum Vacuum bar, 20°C			Saug- +Druckschlauch Suction +pressure hose PTFE	
	6	11,6	6,4	-	130	0,8			6126-6,4	Anfrage
	10	15,5	9,5	-	100	0,8			6126-9,5	Anfrage
	13	19,5	12,7	-	70	0,8			6126-12,7	Anfrage
	20	27,3	19	-	60	0,8			6126-19	Anfrage
	25	34,8	25,4	-	50	0,8			6126-25,4	Anfrage
Nur mit Schlauchstutzen konfektioniert lieferbar. Auch antistatisch mit ableitfähigem schwarzen PTFE lieferbar. Only available with hose nozzles ready-for-use. Also antistatic available with conductive black PTFE.										

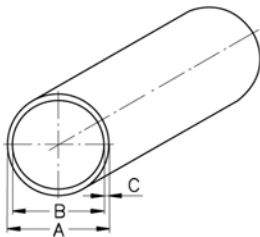

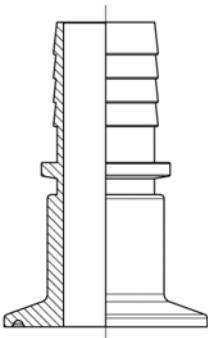
Lebensmittelschläuche							Art.No.	EUR	Art.No.	EUR
Klemmschlauchstutzen DIN 32676 DIN Clamp hose nozzle DIN 32676 DIN 	DN	Ø Flansch flange	Schlauch Hose				AISI316L-1.4404			
	10	34	13x5					620130	Anfrage	
	15	34	13x5					620131	Anfrage	
	20	34	19x6					620132	Anfrage	
	25	50,5	25x6					620133	Anfrage	
	32	50,5	32x6					620134	Anfrage	
	32	50,5	32x8					620153	Anfrage	
	40	50,5	38x6,5					620135	Anfrage	
	40	50,5	40x7					620157	Anfrage	
	40	50,5	40x10					620158	Anfrage	
	50	64	50x8					620136	Anfrage	
	50	64	50x11					620161	Anfrage	
	65	91	65x8					620137	Anfrage	
	65	91	65x12					620163	Anfrage	
	80	106	75x8					620138	Anfrage	
80	106	80x9					620165	Anfrage		
100	119	102x9					620139	Anfrage		

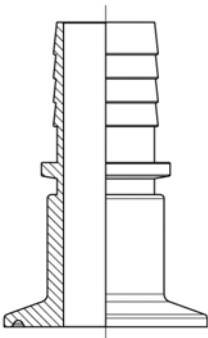
Klemmschlauchstutzen DIN 32676 ASME Clamp hose nozzle DIN 32676 ASME 	DN	Ø Flansch flange	Schlauch Hose				AISI316L-1.4404			
	1/2"	25	13x5					620201	Anfrage	
	3/4"	25	19x6					620202	Anfrage	
	1"	50,5	25x6					620203	Anfrage	
	1,5"	50,5	38x6,5					620204	Anfrage	
	1,5"	50,5	40x7					620266	Anfrage	
	1,5"	50,5	40x10					620267	Anfrage	
	2"	64	50x8					620205	Anfrage	
	2"	64	50x11					620268	Anfrage	
	2,5"	77,5	65x8					620206	Anfrage	
	2,5"	77,5	65x12					620269	Anfrage	
	3"	91	75x8					620207	Anfrage	
	3"	91	80x9					620270	Anfrage	
	4"	119	102x9					620208	Anfrage	

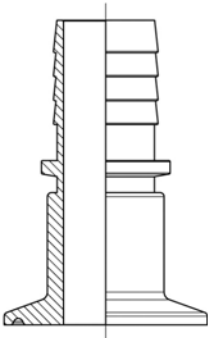
Klemmschlauchstutzen DIN 32676 ISO Clamp hose nozzle DIN 32676 ISO 	DN	Ø Flansch flange	Schlauch Hose				AISI316L-1.4404			
	13,5	25	13x5					620316	Anfrage	
	17,2	25	13x5					620317	Anfrage	
	21,3	50,5	19x5					620318	Anfrage	
	26,9	50,5	19x6					620332	Anfrage	
	26,9	50,5	25x6					620350	Anfrage	
	33,7	50,5	25x6					620333	Anfrage	
	33,7	50,5	32x6					620351	Anfrage	
	33,7	50,5	32x8					620352	Anfrage	
	42,4	64	32x6					620319	Anfrage	
	42,4	64	32x8					620353	Anfrage	
	42,4	64	38x6,5					620354	Anfrage	
	42,4	64	40x7					620355	Anfrage	

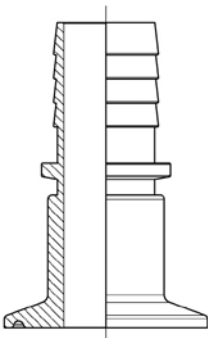
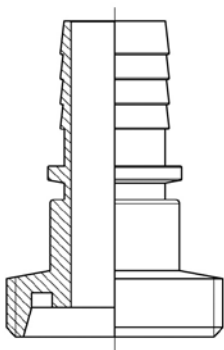
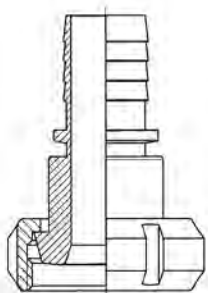

Lebensmittelschläuche							Art.No.	EUR	Art.No.	EUR
<b>Klemmschlauchstutzen DIN 32676 ISO</b> <b>Clamp hose nozzle DIN 32676 ISO</b> 	<b>DN</b>	<b>Ø Flansch flange</b>	<b>Schlauch Hose</b>						<b>AISI316L-1.4404</b>	
	42,4	64	40x10						620356	Anfrage
	48,3	64	38x6,5						620335	Anfrage
	48,3	64	40x7						620357	Anfrage
	48,3	64	40x10						620358	Anfrage
	60,3	77,5	50x8						620336	Anfrage
	60,3	77,5	50x11						620361	Anfrage
	76,1	91	65x8						620337	Anfrage
	76,1	91	65x12						620363	Anfrage
	88,9	106	75x8						620338	Anfrage
	88,9	106	80x9						620365	Anfrage
	114,3	130	102x9						620321	Anfrage
<b>Gewindeschlauchstutzen DIN 11851</b> <b>Threaded hose ferrule DIN 11851</b> 	<b>DN</b>	<b>Schlauch Hose</b>							<b>AISI316L-1.4404</b>	
	10	13x5							620430	Anfrage
	15	13x5							620431	Anfrage
	20	19x6							620432	Anfrage
	25	25x6							620433	Anfrage
	32	32x6							620434	Anfrage
	32	32x8							620453	Anfrage
	40	40x7							620435	Anfrage
	40	40x10							620458	Anfrage
	50	50x8							620436	Anfrage
	50	50x11							620460	Anfrage
	65	65x8							620437	Anfrage
	65	65x12							620463	Anfrage
	80	75x8							620438	Anfrage
	80	80x9							620465	Anfrage
100	102x9							620439	Anfrage	
<b>Kegelschlauchstutzen DIN 11851</b> <b>Conical hose ferrule DIN 11851</b> 	<b>DN</b>	<b>Schlauch Hose</b>							<b>AISI316L-1.4404</b>	
	10	13x5							620530	Anfrage
	15	13x5							620531	Anfrage
	20	19x6							620532	Anfrage
	25	25x6							620533	Anfrage
	32	32x6							620534	Anfrage
	32	32x8							620553	Anfrage
	40	40x7							620535	Anfrage
	40	40x10							620554	Anfrage
	50	50x8							620536	Anfrage
	50	50x11							620560	Anfrage
	65	65x8							620537	Anfrage
	65	65x12							620563	Anfrage
	80	75x8							620538	Anfrage
	80	80x9							620565	Anfrage
100	102x9							620539	Anfrage	

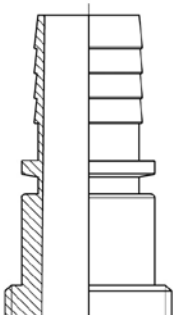
Lebensmittelschläuche							Art.No.	EUR	Art.No.	EUR
<b>SMS Gewindeschlauchstutzen</b> <b>SMS threaded hose ferrule</b> 	DN	Schlauch Hose					AISI316L-1.4404			
	25/1"	25x6					620603		Anfrage	
	38/1,5"	40x7					620604		Anfrage	
	38/1,5"	40x10					620666		Anfrage	
	51/2"	50x8					620605		Anfrage	
	51/2"	50x11					620668		Anfrage	
	63,5/2,5"	65x8					620606		Anfrage	
	63,5/2,5"	65x12					620669		Anfrage	
	76/3"	75x8					620607		Anfrage	
	101,6/4"	102x9					620608		Anfrage	

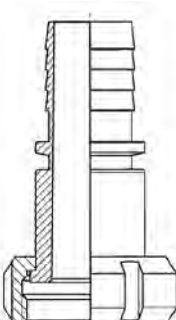
<b>SMS Bundschlauchstutzen</b> <b>SMS linear hose ferrule</b> 	DN	Schlauch Hose					AISI316L-1.4404			
	25/1"	25x6					620703		Anfrage	
	38/1,5"	40x7					620704		Anfrage	
	38/1,5"	40x10					620766		Anfrage	
	51/2"	50x8					620705		Anfrage	
	51/2"	50x11					620768		Anfrage	
	63,5/2,5"	65x8					620706		Anfrage	
	63,5/2,5"	65x12					620769		Anfrage	
	76/3"	75x8					620707		Anfrage	
	101,6/4"	102x9					620708		Anfrage	

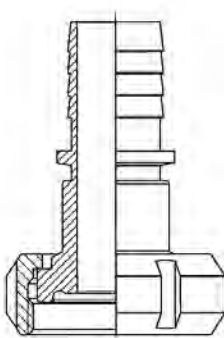
<b>Bundschlauchst. DIN 11864-1 DIN</b> <b>Liner hose nozzle DIN 11864-1 DIN</b> 	DN	Schlauch Hose					AISI316L-1.4404			
	10	13x5					620830		Anfrage	
	15	13x5					620831		Anfrage	
	20	19x6					620832		Anfrage	
	25	25x6					620833		Anfrage	
	32	32x6					620834		Anfrage	
	32	32x8					620853		Anfrage	
	40	40x7					620857		Anfrage	
	40	40x10					620858		Anfrage	
	50	50x8					620836		Anfrage	
	50	50x11					620861		Anfrage	
	65	65x8					620837		Anfrage	
	65	65x12					620863		Anfrage	
	80	75x8					620838		Anfrage	
	80	80x9					620865		Anfrage	
	100	102x9					620839		Anfrage	

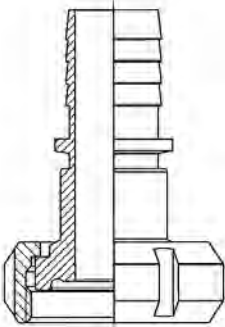
Lebensmittelschläuche							Art.No.	EUR	Art.No.	EUR
<b>Bundschlauchst. DIN 11864-1 ASME</b> Liner hose nozzle DIN 11864-1 ASME 	DN	Schlauch Hose					AISI316L-1.4404			
	1/2"	13x5					620901	Anfrage		
	3/4"	19x6					620902	Anfrage		
	1"	25x6					620903	Anfrage		
	1,5"	38x6,5					620904	Anfrage		
	1,5"	40x7					620966	Anfrage		
	1,5"	40x10					620967	Anfrage		
	2"	50x8					620905	Anfrage		
	2"	50x11					620968	Anfrage		
	2,5"	65x8					620906	Anfrage		
	2,5"	65x12					620969	Anfrage		
	3"	75x8					620907	Anfrage		
	3"	80x9					620970	Anfrage		
4"	102x9					620908	Anfrage			

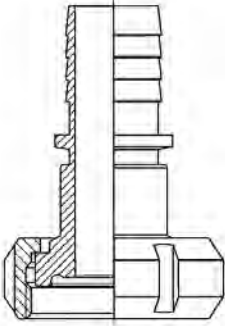
<b>Bundschlauchst. DIN 11864-1 ISO</b> Liner hose nozzle DIN 11864-1 ISO 	DN	Schlauch Hose					AISI316L-1.4404			
	13,5	13x5					621029	Anfrage		
	17,2	13x5					621030	Anfrage		
	21,3	19x5					621031	Anfrage		
	26,9	19x6					621032	Anfrage		
	26,9	25x6					621050	Anfrage		
	33,7	25x6					621033	Anfrage		
	33,7	32x6					621051	Anfrage		
	42,4	38x6,5					621054	Anfrage		
	42,4	40x7					621055	Anfrage		
	42,4	40x10					621056	Anfrage		
	48,3	50x8					621059	Anfrage		
	48,3	50x11					621060	Anfrage		
	60,3	65x8					621062	Anfrage		
	76,1	75x8					621064	Anfrage		
	88,9	80x9					621065	Anfrage		
114,3	102x9					621039	Anfrage			

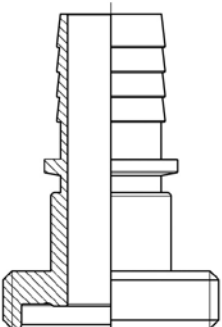
<b>Gewindeschlauchst. DIN 11864-1 DIN</b> Threaded hose nozzle DIN 11864-1 DIN 	DN	Schlauch Hose					AISI316L-1.4404			
	10	13x5					621130	Anfrage		
	15	13x5					621131	Anfrage		
	20	19x6					621132	Anfrage		
	25	25x6					621133	Anfrage		
	32	32x6					621134	Anfrage		
	32	32x8					621153	Anfrage		
	40	40x7					621157	Anfrage		
	40	40x10					621158	Anfrage		
	50	50x8					621136	Anfrage		
	50	50x11					621161	Anfrage		
	65	65x8					621137	Anfrage		
	65	65x12					621163	Anfrage		
	80	75x8					621138	Anfrage		
	80	80x9					621165	Anfrage		

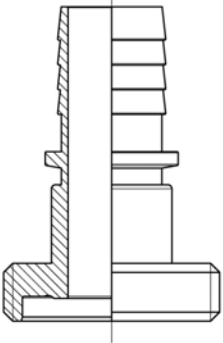
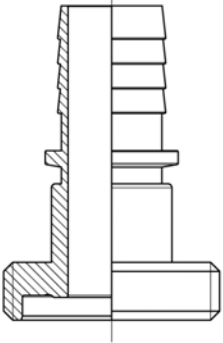
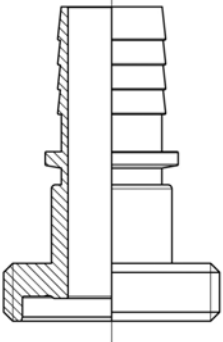
Lebensmittelschläuche						Art.No.	EUR	Art.No.	EUR
Gewindeschlauchst. DIN 11864-1 DIN Threaded hose nozzle DIN 11864-1 DIN  	DN	Schlauch Hose				AISI316L-1.4404			
	100	102x9						621139	Anfrage
Gewindeschlauchst. DIN 11864-1 ASME Threaded hose nozzle DIN 11864-1 ASME  	DN	Schlauch Hose					AISI316L-1.4404		
	1/2"	13x5					621201	Anfrage	
	3/4"	19x6					621202	Anfrage	
	1"	25x6					621203	Anfrage	
	1,5"	38x6,5					621204	Anfrage	
	1,5"	40x7					621266	Anfrage	
	1,5"	40x10					621267	Anfrage	
	2"	50x8					621205	Anfrage	
	2"	50x11					621268	Anfrage	
	2,5"	65x8					621206	Anfrage	
	2,5"	65x12					621269	Anfrage	
	3"	75x8					621207	Anfrage	
	3"	80x9					621270	Anfrage	
	4"	102x9					621208	Anfrage	
Gewindeschlauchst. DIN 11864-1 ISO Threaded hose nozzle DIN 11864-1 ISO  	DN	Schlauch Hose					AISI316L-1.4404		
	13,5	13x5					621329	Anfrage	
	17,2	13x5					621330	Anfrage	
	21,3	19x5					621331	Anfrage	
	26,9	19x6					621332	Anfrage	
	26,9	25x6					621350	Anfrage	
	33,7	25x6					621333	Anfrage	
	33,7	32x6					621351	Anfrage	
	42,4	38x6,5					621354	Anfrage	
	42,4	40x7					621355	Anfrage	
	42,4	40x10					621356	Anfrage	
	48,3	50x8					621359	Anfrage	
	48,3	50x11					621360	Anfrage	
	60,3	65x8					621362	Anfrage	
	76,1	75x8					621364	Anfrage	
	88,9	80x9					621365	Anfrage	
114,3	102x9					621339	Anfrage		

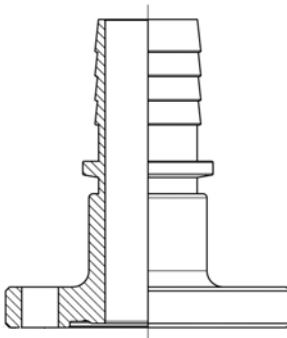
Lebensmittelschläuche							Art.No.	EUR	Art.No.	EUR
<b>Bundfl.-schlauchst. DIN 11864-2 DIN</b> Notch flange hose nozzle DIN 11864-2 DIN 	DN	Schlauch Hose					AISI316L-1.4404			
	10	13x5					621430		Anfrage	
	15	13x5					621431		Anfrage	
	20	19x6					621432		Anfrage	
	25	25x6					621433		Anfrage	
	32	32x6					621434		Anfrage	
	40	38x6,5					621435		Anfrage	
	40	40x7					621457		Anfrage	
	50	50x8					621436		Anfrage	
	65	65x8					621437		Anfrage	
	80	75x8					621438		Anfrage	
	80	80x9					621465		Anfrage	
	100	102x9					621439		Anfrage	

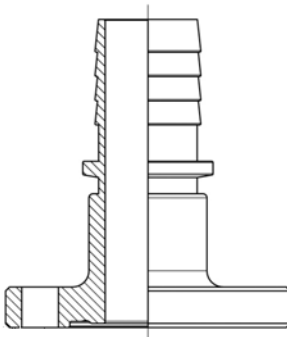
<b>Bundfl.-schlauchst. DIN 11864-2 ASME</b> Notch flange hose nozzle DIN 11864-2 ASME 	DN	Schlauch Hose					AISI316L-1.4404			
	1/2"	13x5					621501		Anfrage	
	3/4"	19x6					621502		Anfrage	
	1"	25x6					621503		Anfrage	
	1,5"	38x6,5					621504		Anfrage	
	1,5"	40x7					621566		Anfrage	
	2"	50x8					621505		Anfrage	
	2,5"	65x8					621506		Anfrage	
	3"	75x8					621507		Anfrage	
	3"	80x9					621570		Anfrage	
	4"	102x9					621508		Anfrage	

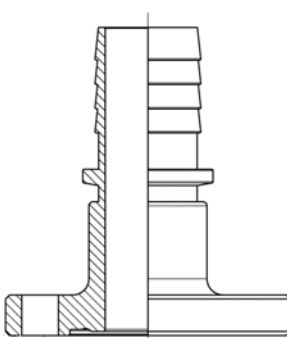
<b>Bundfl.-schlauchst. DIN 11864-2 ISO</b> Notch flange hose nozzle DIN 11864-2 ISO 	DN	Schlauch Hose					AISI316L-1.4404			
	13,5	13x5					621629		Anfrage	
	17,2	13x5					621630		Anfrage	
	21,3	19x5					621631		Anfrage	
	26,9	19x6					621632		Anfrage	
	26,9	25x6					621650		Anfrage	
	33,7	25x6					621633		Anfrage	
	33,7	32x6					621651		Anfrage	
	42,4	32x6					621634		Anfrage	
	42,4	38x6,5					621654		Anfrage	
	42,4	40x7					621655		Anfrage	
	48,3	38x6,5					621635		Anfrage	
	48,3	40x7					621657		Anfrage	
	60,3	50x8					621636		Anfrage	
	76,1	65x8					621637		Anfrage	
	76,1	75x8					621664		Anfrage	
	88,9	75x8					621638		Anfrage	
88,9	80x9					621665		Anfrage		
114,3	102x9					621639		Anfrage		

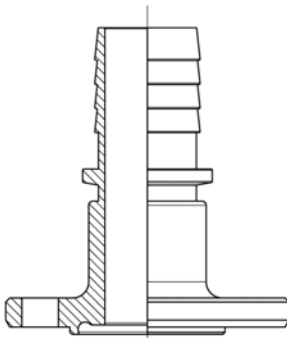
Lebensmittelschläuche							Art.No.	EUR	Art.No.	EUR
<b>Nutfl.-schlauchst. DIN 11864-2 DIN</b> Groove fl. hose nozzle DIN 11864-2 DIN 	DN	Schlauch Hose					AISI316L-1.4404			
	10	13x5					621730		Anfrage	
	15	13x5					621731		Anfrage	
	20	19x6					621732		Anfrage	
	25	25x6					621733		Anfrage	
	32	32x6					621734		Anfrage	
	40	38x6,5					621735		Anfrage	
	40	40x7					621757		Anfrage	
	50	50x8					621736		Anfrage	
	65	65x8					621737		Anfrage	
	80	75x8					621738		Anfrage	
	80	80x9					621765		Anfrage	
	100	102x9					621739		Anfrage	

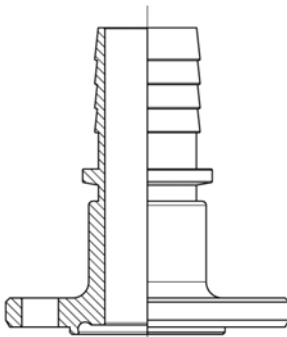
<b>Nutfl.-schlauchst. DIN 11864-2 ASME</b> Groove fl. hose nozzle DIN 11864-2 ASME 	DN	Schlauch Hose					AISI316L-1.4404			
	1/2"	13x5					621801		Anfrage	
	3/4"	19x6					621802		Anfrage	
	1"	25x6					621803		Anfrage	
	1,5"	38x6,5					621804		Anfrage	
	1,5"	40x7					621866		Anfrage	
	2"	50x8					621805		Anfrage	
	2,5"	65x8					621806		Anfrage	
	3"	75x8					621807		Anfrage	
	3"	80x9					621870		Anfrage	
	4"	102x9					621808		Anfrage	

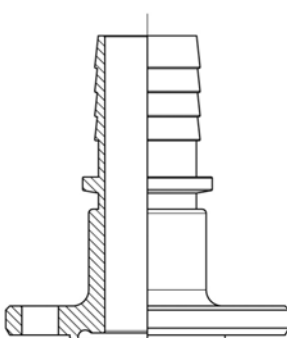
<b>Nutfl.-schlauchst. DIN 11864-2 ISO</b> Groove fl. hose nozzle DIN 11864-2 ISO 	DN	Schlauch Hose					AISI316L-1.4404			
	13,5	13x5					621929		Anfrage	
	17,2	13x5					621930		Anfrage	
	21,3	19x5					621931		Anfrage	
	26,9	19x6					621932		Anfrage	
	26,9	25x6					621950		Anfrage	
	33,7	25x6					621933		Anfrage	
	33,7	32x6					621951		Anfrage	
	42,4	32x6					621934		Anfrage	
	42,4	38x6,5					621954		Anfrage	
	42,4	40x7					621955		Anfrage	
	48,3	38x6,5					621935		Anfrage	
	48,3	40x7					621957		Anfrage	
	60,3	50x8					621936		Anfrage	
	76,1	65x8					621937		Anfrage	
	76,1	75x8					621964		Anfrage	
	88,9	75x8					621938		Anfrage	
88,9	80x9					621965		Anfrage		
114,3	102x9					621939		Anfrage		

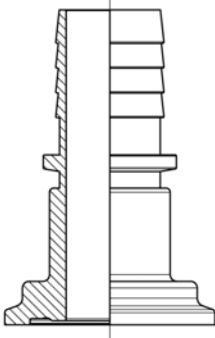
Lebensmittelschläuche							Art.No.	EUR	Art.No.	EUR
<b>Bundkl.-schlauchst. DIN 11864-3 DIN</b> Notch clamp hose nozzle DIN 11864-3 DIN 	DN	Schlauch Hose					AISI316L-1.4404			
	10	13x5					622030	Anfrage		
	15	13x5					622031	Anfrage		
	20	19x6					622032	Anfrage		
	25	25x6					622033	Anfrage		
	32	32x6					622034	Anfrage		
	32	32x8					622053	Anfrage		
	40	38x6,5					622035	Anfrage		
	40	40x7					622057	Anfrage		
	50	50x8					622036	Anfrage		
	65	65x8					622037	Anfrage		
	80	75x8					622038	Anfrage		
	80	80x9					622065	Anfrage		
	100	102x9					622039	Anfrage		

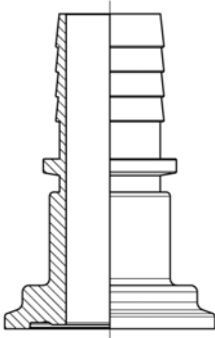
<b>Bundkl.-schlauchst. DIN 11864-3 ASME</b> Notch clamp hose nozzle DIN 11864-3 ASME 	DN	Schlauch Hose					AISI316L-1.4404			
	1/2"	13x5					622101	Anfrage		
	3/4"	19x6					622102	Anfrage		
	1"	25x6					622103	Anfrage		
	1,5"	38x6,5					622104	Anfrage		
	1,5"	40x7					622166	Anfrage		
	2"	50x8					622105	Anfrage		
	2,5"	65x8					622106	Anfrage		
	3"	75x8					622107	Anfrage		
	3"	80x9					622170	Anfrage		
	4"	102x9					622108	Anfrage		

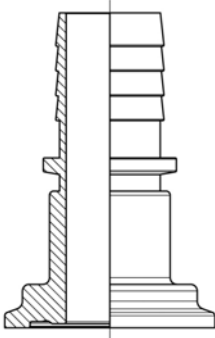
<b>Bundkl.-schlauchst. DIN 11864-3 ISO</b> Notch clamp hose nozzle DIN 11864-3 ISO 	DN	Schlauch Hose					AISI316L-1.4404			
	13,5	13x5					622229	Anfrage		
	17,2	13x5					622230	Anfrage		
	21,3	19x5					622218	Anfrage		
	26,9	19x6					622232	Anfrage		
	26,9	25x6					622250	Anfrage		
	33,7	25x6					622233	Anfrage		
	33,7	32x6					622251	Anfrage		
	42,4	32x6					622234	Anfrage		
	42,4	38x6,5					622254	Anfrage		
	42,4	40x7					622255	Anfrage		
	48,3	38x6,5					622235	Anfrage		
	48,3	40x7					622257	Anfrage		
	60,3	50x8					622236	Anfrage		
	76,1	65x8					622237	Anfrage		
	76,1	75x8					622264	Anfrage		
	88,9	75x8					622238	Anfrage		
	88,9	80x9					622265	Anfrage		
114,3	102x9					622239	Anfrage			

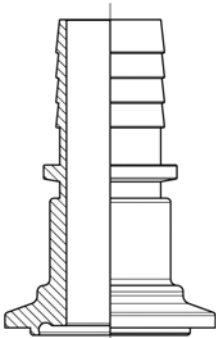
Lebensmittelschläuche							Art.No.	EUR	Art.No.	EUR
<b>Nutkl.-schlauchst. DIN 11864-3 DIN</b> Groove clamp hose nozzle DIN 11864-3 DIN 	DN	Schlauch Hose					AISI316L-1.4404			
	10	13x5					622330		Anfrage	
	15	13x5					622331		Anfrage	
	20	19x6					622332		Anfrage	
	25	25x6					622333		Anfrage	
	32	32x6					622334		Anfrage	
	40	38x6,5					622335		Anfrage	
	40	40x7					622357		Anfrage	
	50	50x8					622336		Anfrage	
	65	65x8					622337		Anfrage	
	80	75x8					622338		Anfrage	
	80	80x9					622365		Anfrage	
100	102x9					622339		Anfrage		

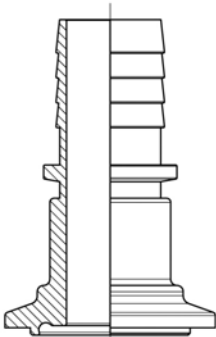
<b>Nutkl.-schlauchst. DIN 11864-3 ASME</b> Groove clamp hose nozzle DIN 11864-3 ASME 	DN	Schlauch Hose					AISI316L-1.4404			
	1/2"	13x5					622401		Anfrage	
	3/4"	19x6					622402		Anfrage	
	1"	25x6					622403		Anfrage	
	1,5"	38x6,5					622404		Anfrage	
	1,5"	40x7					622466		Anfrage	
	2"	50x8					622405		Anfrage	
	2,5"	65x8					622406		Anfrage	
	3"	75x8					622407		Anfrage	
	3"	80x9					622470		Anfrage	
	4"	102x9					622408		Anfrage	

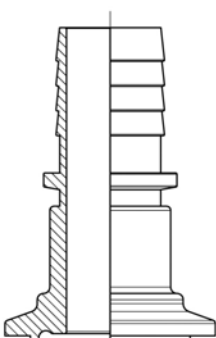
<b>Nutkl.-schlauchst. DIN 11864-3 ISO</b> Groove clamp hose nozzle DIN 11864-3 ISO 	DN	Schlauch Hose					AISI316L-1.4404			
	13,5	13x5					622529		Anfrage	
	17,2	13x5					622530		Anfrage	
	21,3	19x5					622518		Anfrage	
	26,9	19x6					622532		Anfrage	
	26,9	25x6					622550		Anfrage	
	33,7	25x6					622533		Anfrage	
	33,7	32x6					622551		Anfrage	
	42,4	32x6					622534		Anfrage	
	42,4	38x6,5					622554		Anfrage	
	42,4	40x7					622555		Anfrage	
	48,3	38x6,5					622535		Anfrage	
	48,3	40x7					622557		Anfrage	
	60,3	50x8					622536		Anfrage	
	76,1	65x8					622537		Anfrage	
	76,1	75x8					622564		Anfrage	
	88,9	75x8					622538		Anfrage	
	88,9	80x9					622565		Anfrage	
114,3	102x9					622539		Anfrage		

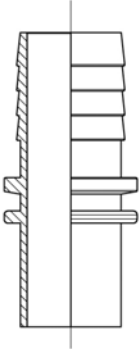

Lebensmittelschläuche						Art.No.	EUR	Art.No.	EUR
<b>Rohr-Schlauchstutzen DIN 11850</b> <b>Tube hose nozzle DIN 11850</b> 	DN	Schlauch Hose	Rohr Tube	Rohrläng Tube length			AISI316L-1.4404		
	10	13x5	13x1,5	25			622630	Anfrage	
	15	13x5	19x1,5	25			622631	Anfrage	
	15	19x6	19x1,5	25			622618	Anfrage	
	20	19x6	23x1,5	25			622632	Anfrage	
	25	25x6	29x1,5	25			622633	Anfrage	
	32	32x6	35x1,5	25			622634	Anfrage	
	32	32x8	35x1,5	25			622652	Anfrage	
	40	38x7	41x1,5	25			622635	Anfrage	
	40	40x7	41x1,5	25			622657	Anfrage	
	40	40x10	41x1,5	25			622658	Anfrage	
	50	50x8	53x1,5	25			622636	Anfrage	
	50	50x11	53x1,5	25			622660	Anfrage	
	65	65x8	70x2,0	25			622637	Anfrage	
	80	75x8	84x2,0	25			622638	Anfrage	
	80	80x9	84x2,0	25			622665	Anfrage	
100	102x9	104x2,0	25			622639	Anfrage		

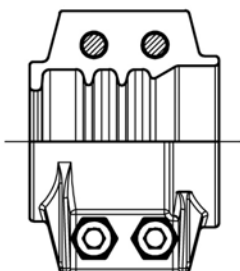
<b>Klemmschalen DIN 2827</b> <b>Hose clamp colars DIN 2827</b> 	DN	Ø Schlauch aussen Hose outside				AISI304		Aluminium		
	10	22-24				630201	Anfrage	630101	Anfrage	
	15	30-33				630202	Anfrage	630102	Anfrage	
	25	34-38						630104	Anfrage	
	25	36-39				630205	Anfrage	630105	Anfrage	
	32	42-45						630106	Anfrage	
	32	43-46				630207	Anfrage	630107	Anfrage	
	32	47-50				630208	Anfrage	630108	Anfrage	
	38	50-52				630209	Anfrage	630109	Anfrage	
	38	53-56						630110	Anfrage	
	40	53-56						630111	Anfrage	
	40	58-61				630212	Anfrage	630112	Anfrage	
	50	61-63				630213	Anfrage	630113	Anfrage	
	50	64-67				630214	Anfrage	630114	Anfrage	
	50	69-71				630215	Anfrage	630115	Anfrage	
	65	75-78				630216	Anfrage	630116	Anfrage	
	65	78-82				630217	Anfrage	630117	Anfrage	
	65	84-87						630118	Anfrage	
	75	89-93				630219	Anfrage	630119	Anfrage	
	75	94-97						630120	Anfrage	
	80	94-97						630121	Anfrage	
	80	99-102						630122	Anfrage	
	100	114-119				630223	Anfrage	630123	Anfrage	
	100	118-122						630124	Anfrage	
	100	122-126						630125	Anfrage	
	125	143-148						630127	Anfrage	
125	149-154						630128	Anfrage		
150	168-174						630129	Anfrage		

Lebensmittelschläuche							Art.No.	EUR	Art.No.	EUR
<b>Klemmschalen DIN 2827</b> Hose clamp colars DIN 2827	DN	Ø Schlauch ausse Hose outside					AISI304		Aluminium	
	150	174-180						630130	Anfrage	

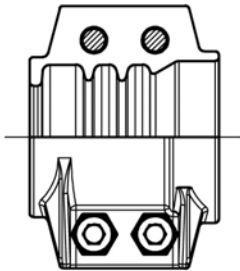

<b>Presshülsen</b> Press shell	DN	Ø Schlauch ausse Hose outside						AISI304	
	10	22-24							630301
15	30-33							630302	Anfrage
25	34-38							630304	Anfrage
25	36-39							630305	Anfrage
32	43-46							630307	Anfrage
32	47-50							630308	Anfrage
38	50-52							630309	Anfrage
38	53-56							630310	Anfrage
40	53-56							630311	Anfrage
40	58-61							630312	Anfrage
50	64-67							630314	Anfrage
50	69-71							630315	Anfrage
65	78-82							630317	Anfrage
75	89-93							630319	Anfrage
80	94-97							630321	Anfrage
100	114-119							630323	Anfrage

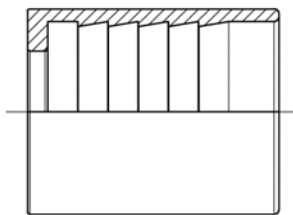

<b>Schlauchklemme, Breite 9 mm</b> Hose clip, width 9 mm	DN	Ø Schlauch ausse Hose outside						AISI304	
	15	16-25							630402
20	20-32							630403	Anfrage
25	25-40							630404	Anfrage
32	32-50							630406	Anfrage
40	40-60							630411	Anfrage
50	50-70							630413	Anfrage
50	60-80							630414	Anfrage
65	70-90							630416	Anfrage
75	80-100							630419	Anfrage
80	90-110							630421	Anfrage
100	100-120							630423	Anfrage

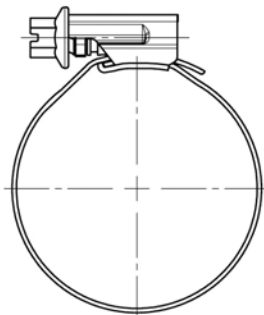

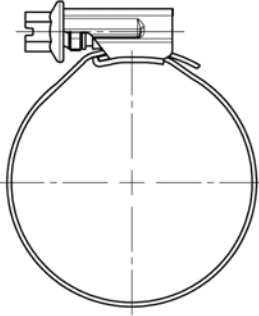
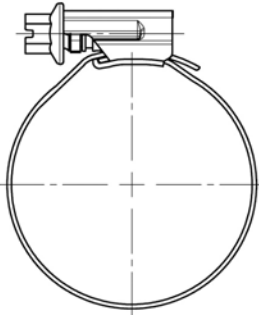
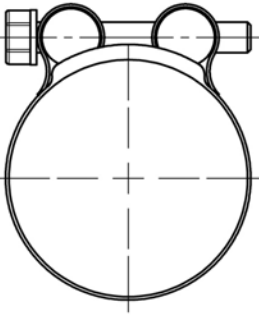
Lebensmittelschläuche							Art.No.	EUR	Art.No.	EUR
<b>Schlauchklemme, Breite 9 mm</b> Hose clip, width 9 mm  	DN	Ø Schlauch ausen Hose outside						AISI304		
	100	110-130						630424	Anfrage	
	100	120-140						630425	Anfrage	
<b>Schlauchklemme, Breite 12 mm</b> Hose clip, width 12 mm  	DN	Ø Schlauch ausen Hose outside						AISI304		
	15	16-25						630502	Anfrage	
	20	20-32						630503	Anfrage	
	25	25-40						630504	Anfrage	
	32	32-50						630506	Anfrage	
	40	40-60						630511	Anfrage	
	50	50-70						630513	Anfrage	
	50	60-80						630514	Anfrage	
	65	70-90						630516	Anfrage	
	75	80-100						630519	Anfrage	
	80	90-110						630521	Anfrage	
	100	100-120						630523	Anfrage	
	100	110-130						630524	Anfrage	
	100	120-140						630525	Anfrage	
115	130-150						630515	Anfrage		
<b>Spannbackenschelle</b> Chuck clip  	DN	Ø Schlauch ausen Hose outside						AISI304		
	10	23-25						630601	Anfrage	
	15	26-28						630602	Anfrage	
	20	29-31						630603	Anfrage	
	25	32-35						630604	Anfrage	
	25	36-39						630605	Anfrage	
	32	40-43						630606	Anfrage	
	32	44-47						630607	Anfrage	
	32	48-51						630608	Anfrage	
	40	52-55						630610	Anfrage	
	50	56-59						630612	Anfrage	
	50	60-63						630613	Anfrage	
	50	64-67						630614	Anfrage	
	50	68-73						630615	Anfrage	

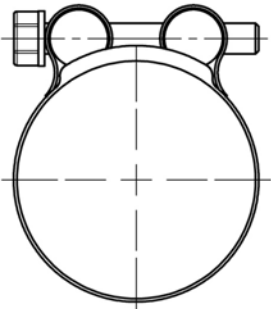
Lebensmittelschläuche							Art.No.	EUR	Art.No.	EUR
<b>Spannbackenschelle</b> <b>Chuck clip</b>  	DN	Ø Schlauch ausser Hose outside					AISI304			
	65	74-79					630616	Anfrage		
	65	80-85					630617	Anfrage		
	80	86-91					630619	Anfrage		
	80	92-97					630620	Anfrage		
	80	98-103					630621	Anfrage		
	100	104-112					630622	Anfrage		
	100	113-121					630623	Anfrage		
	100	122-130					630625	Anfrage		
	115	131-139					630626	Anfrage		
	125	140-148					630627	Anfrage		
	125	149-161					630628	Anfrage		
	150	162-174					630629	Anfrage		
	150	175-187					630630	Anfrage		

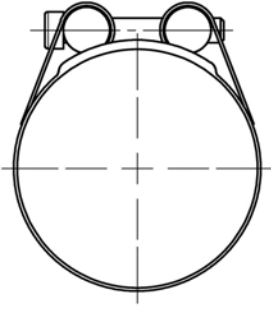
<b>Schlauchklemme Pa-Ri, 1-teilig</b> <b>Hose clip Pa-Ri, 1-piece</b>  	DN	Ø Schlauch ausser Hose outside					AISI304			
	25	30-36					630704	Anfrage		
	32	35-41					630705	Anfrage		
	32	40-46					630706	Anfrage		
	40	45-51					630708	Anfrage		
	40	50-56					630710	Anfrage		
	40	53-59					630711	Anfrage		
	50	55-61					630712	Anfrage		
	50	60-67					630714	Anfrage		
	65	65-72					630715	Anfrage		
	65	70-77					630716	Anfrage		
	65	75-82					630717	Anfrage		
	65	80-87					630718	Anfrage		
	75	85-92					630719	Anfrage		
	75	90-97					630720	Anfrage		
	80	95-102					630721	Anfrage		
	80	98-109					630722	Anfrage		
	100	105-112					630723	Anfrage		
	100	110-117					630724	Anfrage		

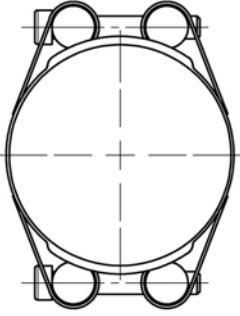
Lebensmittelschläuche							Art.No.	EUR	Art.No.	EUR
Schlauchklemme Pa-Ri, 2-teilig Hose clip Pa-Ri, 2-piece  	DN	Ø Schlauch ausser Hose outside							AISI304	
	32	42-54						630807	Anfrage	
	32	47-57						630808	Anfrage	
	38	52-64						630809	Anfrage	
	40	57-69						630812	Anfrage	
	40	62-74						630814	Anfrage	
	50	67-79						630815	Anfrage	
	50	72-84						630816	Anfrage	
	50	77-89						630817	Anfrage	
	65	82-94						630818	Anfrage	
	75	87-99						630819	Anfrage	
	75	92-104						630820	Anfrage	
	80	97-109						630821	Anfrage	
	80	102-114						630822	Anfrage	
	100	107-119						630823	Anfrage	
	100	112-124						630824	Anfrage	